



**SENZANI**

From innovation to pack



**DISPLAY &  
TRAY PACKERS**

**TP40**

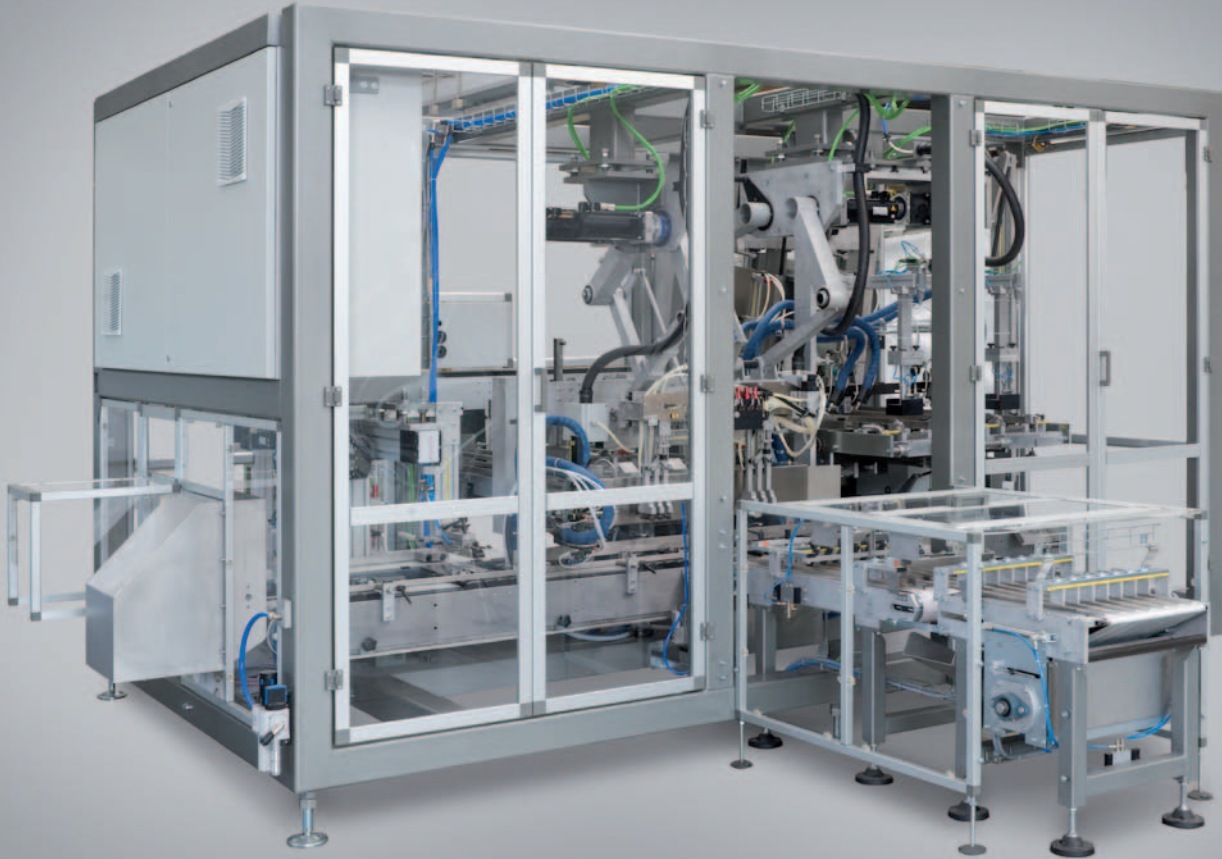

The Senzani TP40 is a **monoblock, “form & fill” display/tray packer** suitable to handle both **cartons** and **displays/trays**. Its main feature is the variety of products that it can pack, even at high speeds.

The machine is made-up of the following main groups:

- Single or double, inclined flat blank magazine
- Picking system with articulated arm.
- Lateral side flap gluing with hot melt injection device.
- Forming unit.
- Positive carton handling.
- **Filling system through an integrated Senzani design “pick & place”.**
- Top flap gluing with hot melt injection device.
- **Lid module.**
- Closing station.
- Reject station.



## TECHNICAL DATA

MAXIMUM FLAT BLANK

750x750 mm.

SPEED

up to 120 cpm

GROSS WEIGHT

14000 kg

COMPRESSED AIR

400NL/min

INSTALLED POWER

29Kw

## WORKING FLOW

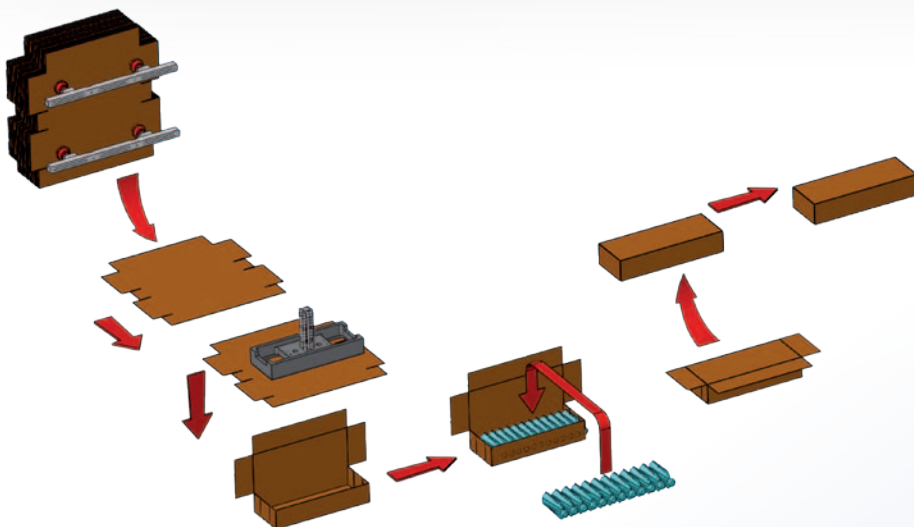

PICK&PLACE FILLING



## LAY-OUT OVERVIEW

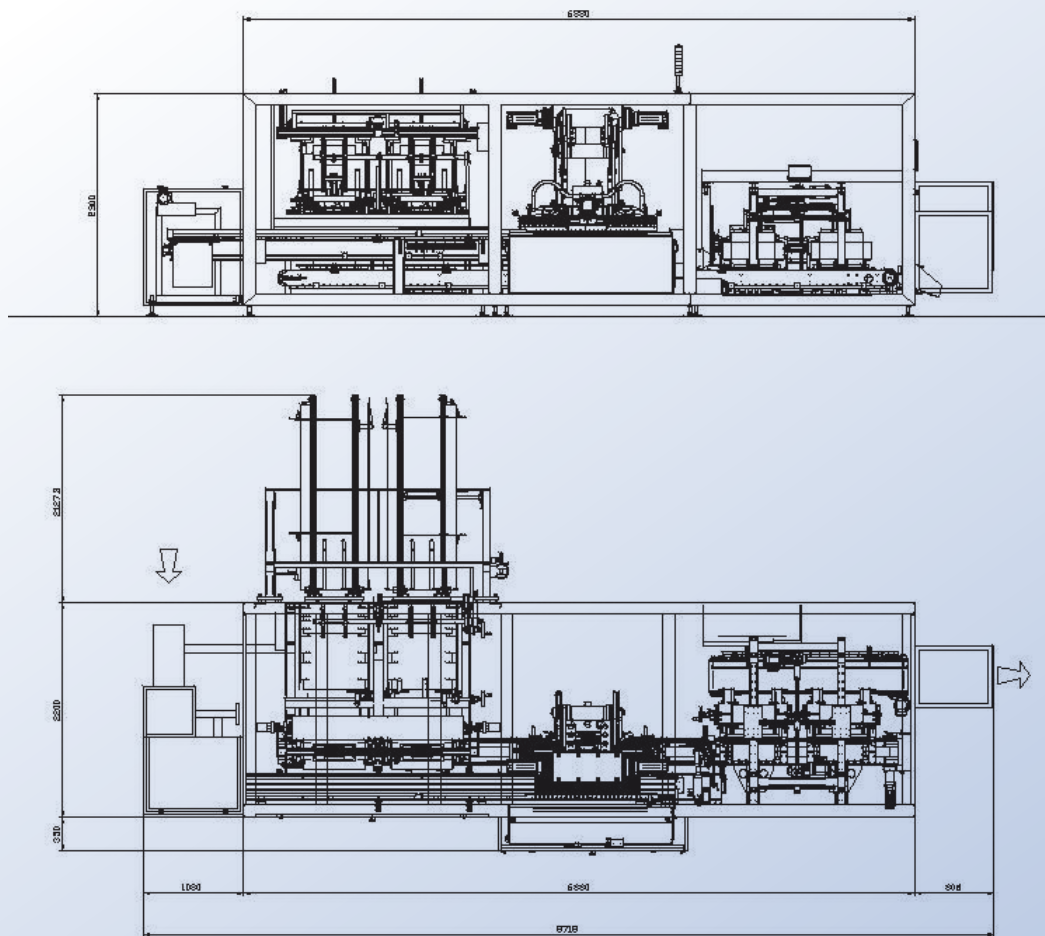

**SENZANI**  
From innovation to pack

Senzani Brevetti S.p.A.

Via Risorgimento 13/15 48018 Faenza (Ra) Italy  
tel. +39-0546 624011 fax +39-0546 621316  
info@senzani.com - www.senzani.com